

## Installation Guide

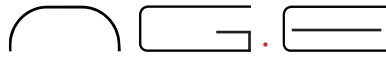

Please carefully read this pre-installation guide before attempting to book or install your Conti Espresso Machine. This simple guide is designed to give you all of the information you'll need to prepare for your machines arrival. Once you've completed your pre installation checklist, please sign and return to your Conti Distributor

## Machine Specifications

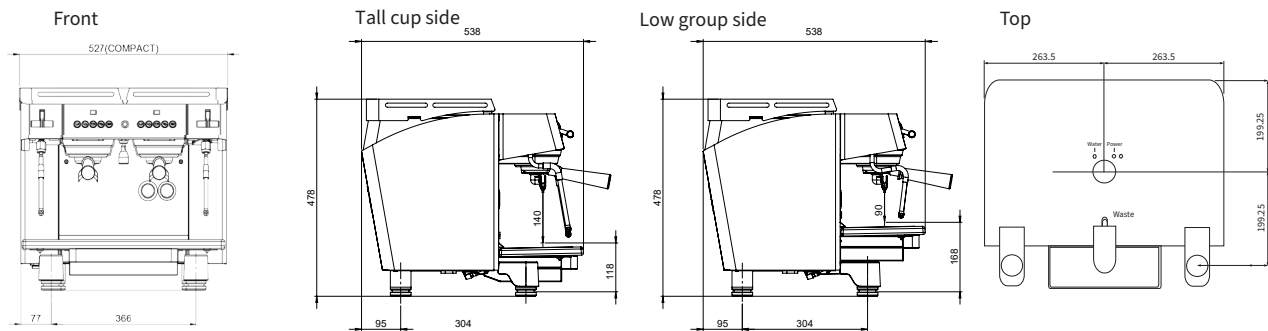

## Counter Top Drilling

When preparing to drill your counter top, the primary consideration is that the waste hose requires a continuous drop. An 80mm hole is the minimum size you will need, the utility and cables are all flexible, therefore a central positioned hole would provide the best access and will minimise drilling

NG-E	1GRP	2GRP COMPACT
MACHINE TOTAL POWER (W)	2200/2700w	2700W
VOLTAGE (V) *	230V	230V
RECOMMENED ELECTRICAL BREAKER (A)	13A	13A
3 PHASE OPTION	NO	NO
BOILER SIZE (L)	5	7
WEIGHT (WITH WATER)	TBA	55

\* PLEASE NOTE THAT ALL MACHINES HAVE BEEN RATED AND CLASSIFIED AT 230V, PLEASE ENSURE VOLTAGE IS MEASURED

## Delivery

Prior to your delivery, your machine is wet tested by our in house technician, undergoing testing and quality control. This is to ensure that your machine is in perfect working condition prior to installation. This means that the machine will be at the operational weight. Please consider this when making provisions to move the machine.

Upon receipt of the machine, please inspect the package carefully for any damage. Any damages must be reported within 24 hours of delivery. We do not recommend removing anything from the shipping crate prior to installation unless instructed to do so.

### Preferred Work Station Layout

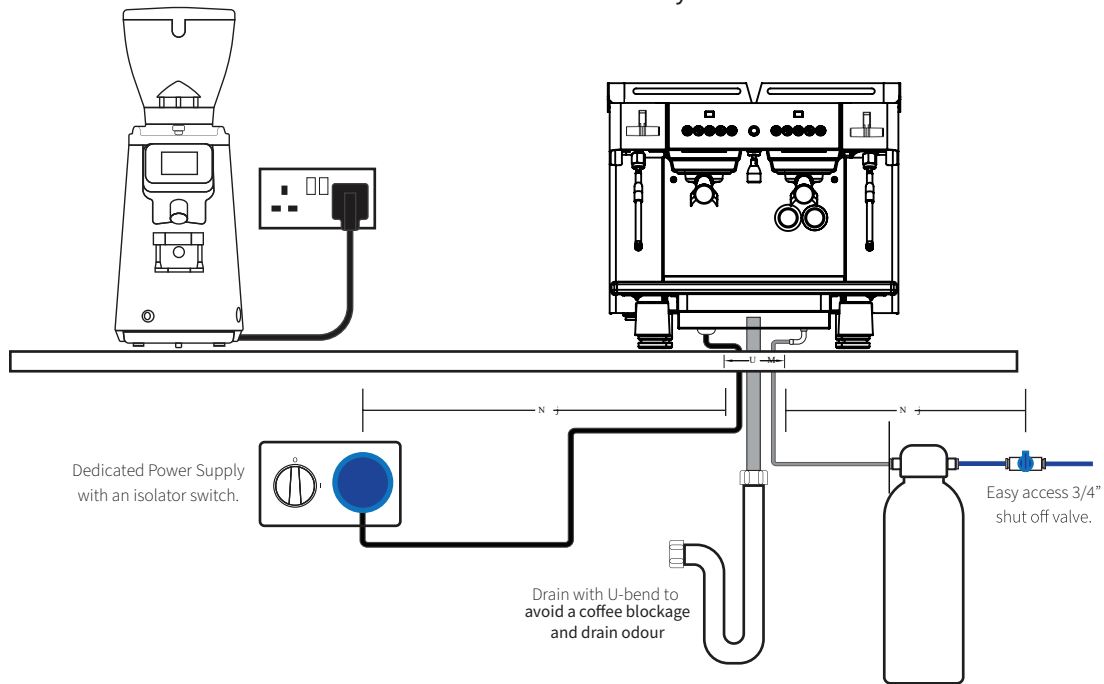

### Pre-Installation Checklist

- A dedicated electrical supply within 1 meter of the final machine location is installed. (for power requirements refer to the table on page 1)
- A dedicated cold water supply terminating within 1 meter of the final machine location, fitted with a 3/4" washing machine fitting and shut of valve is available.
- A straight upstand and U-bend is fitted directly under the machine, under the counter. If plumbed waste isn't available, please make sure that a suitable container is available to collect waste water.
- Both the electrical and plumbing services are tested and are working.
- There is space under the counter clear for access to the water, waste and power supply. (Move utilities). Space is also required for a water treatment unit. Approx 525mm H x 175mm W.
- There is a standard 13A 3 pin socket for the coffee grinder installed above the counter.
- A minimum size of 80mm hole is drilled into the counter to accept the water, power and waste feeds. (Installation technicians can only drill soft wooden surfaces by prior arrangement only)
- A suitable person will be on site to assist with lifting equipment from the crate.
- The worktop is capable of supporting 150KG minimum.
- There is enough space to accomodate the work area outlined in the above diagram.
- Coffee, cups and milk will be on site for callibration.

I understand that by signing, all of the points detailed above are correct and ready. Should any of the above not be fulfilled, I understand that this may result in additional cost or an aborted installation charge of £130+vat.  
 If you are unsure of anything, please contact your Conti distributor.  
 (Site ready photos are encouraged.)

Name:

Signature:

Date: